

Supplementary Yamaha YZF R1 2009-14



1) Ignition coils connector: located on the right side, above engine, beside frame - pic. (A).

- Remove Red/Black wire from female connector (unlock pin by needle). Place Yellow wire from QS unit to this position (where was Red/Black).
- Remove rubber seal in female connector corner and place Red/Black wire (female-pin) here.
- Remove rubber seal in male connector corner and place Red wire from QS unit.

Check if: a) Red/black wire from MOTORCYCLE is connected to RED from QS unit now.
b) Red/black wire to COILS is connected with YELLOW wire from QS unit now.

1b) Ignition coil connector: this connection is necessary for RPM functions only

Remove Grey/Green wire from main-harness connector (female pin). Place (Blue+Violet) wire from QS unit to this place. Insert female Grey/Green into 1pin connector on Violet wire from QS unit

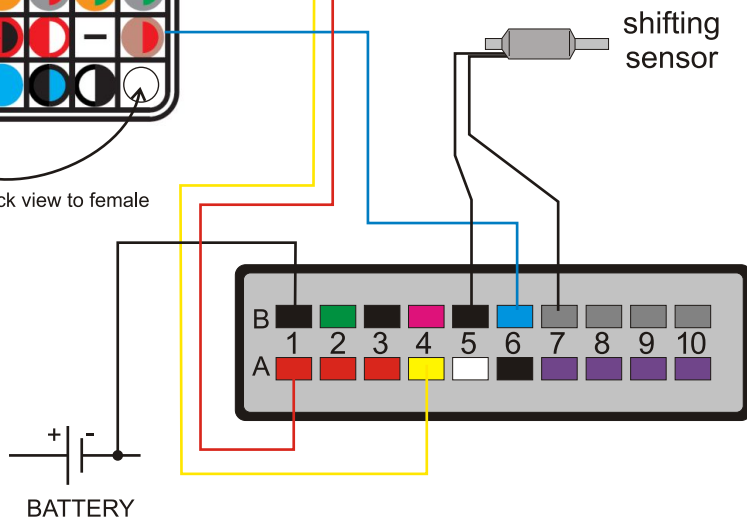
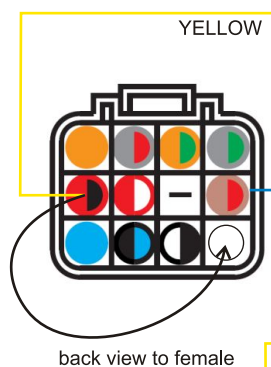
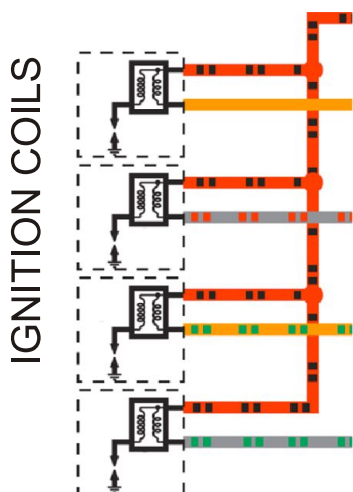
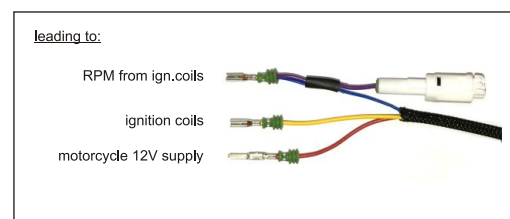
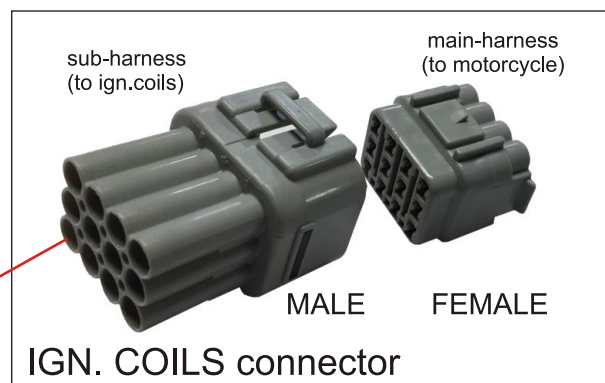
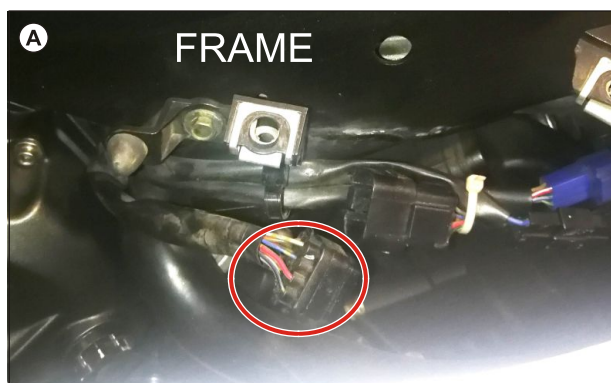



2) **Injectors connector:** located under the fuel tank - pic. (B).

Remove Red/Blue wire from 3way main-harness connector (male pin). Place White wire (male-pin) from QS unit to free position (where was Red/Blue). Use plastic cup to Red/Blue male pin.

3) Connect black wire from QS unit to minus terminal on battery.

4) Connect shifting sensor coupler to QS unit wiring harness.

- Black 2way connector for upwards shifting system (QS)

- White 2way connector for upwards and downwards shifting system (QS+AB)

Plastic cup for Red/Blue male pin



For AUTOBLIPPER only:

5) **Throttle actuator modul:** disconnect connector of throttle actuator position sensor (on throttle body) - pic. (C)

Insert actuator modul.

